

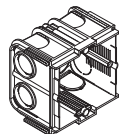

Accessori/Accessories/Accessoires/Accesorios/Zubehör

• ELECTRICAL BOX



D.BOX.034.XX
for
9200R

Scatola elettrica 502E
Electrical box 502E
Boîte électrique 502E
Caja electrica 502E
Elektrische Box 502E

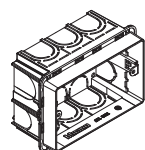

D.BOX.035.XX
for
9201R - 9202R

Scatola elettrica 503E
Electrical box 503E
Boîte électrique 503E
Caja electrica 503E
Elektrische Box 503E

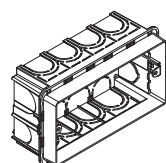

D.BOX.036.XX
for
9201R - 9202R

Scatola elettrica 504E
Electrical box 504E
Boîte électrique 504E
Caja electrica 504E
Elektrische Box 504E

• REMOTE DRIVER

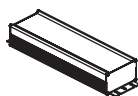

Driver Remoto 24V IP67
24V IP67 Remote Power Supply
Alimentation 24V IP67 à distance
24V IP67 Controlador remoto
24V IP67 Remote-Stromversorgung

E.TRA.577 : Driver 25W 24Vdc

E.TRA.579 : Driver 100W 24Vdc

E.TRA.633 : Driver DALI2 100W 24Vdc

• BOX DRIVER

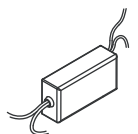

Driver Remoto 24V IP67
24V IP67 Remote Power Supply
Alimentation 24V IP67 à distance
24V IP67 Controlador remoto
24V IP67 Remote-Stromversorgung

E.TRA.646 : Driver 6W 24Vdc for 9200R

E.TRA.647 : Driver 12W 24Vdc for 9201R - 9202R

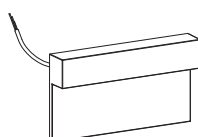

Apparecchio fornito di cavo L=0.3m tipo H05RN 2x0.75mm²
Luminaire supplied with cable L=0.3m type H05RN 2x0.75mm²
Luminaire fourni avec câble de type H05RN 2x0.75mm² L=0.3m
Luminaria suministrada con cable L=0.3m tipo H05RN 2x0.75mm²
Leuchte mit Kabel geliefert L=0.3m H05RN 2x0.75mm²

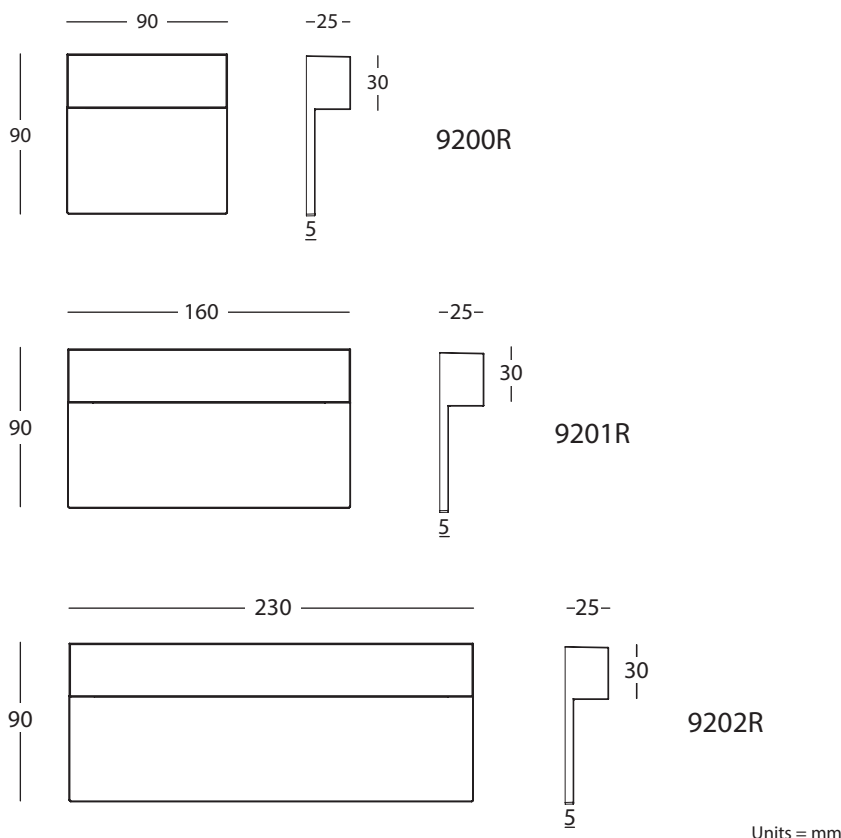

9200R

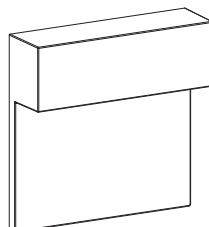

CODE LIGHT WAYS

ALL



9201R

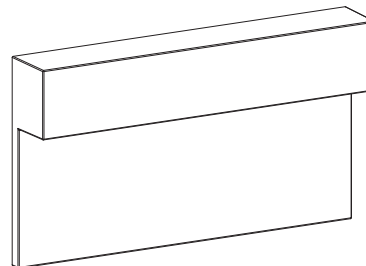

9202R

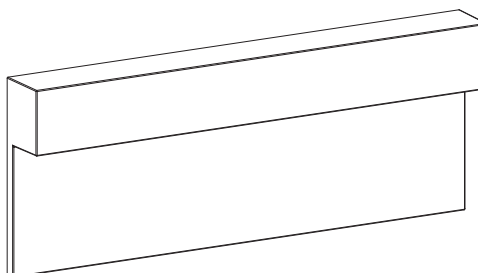



L'installazione dell'apparecchio e tutti gli interventi successivi devono essere effettuati soltanto da personale specializzato nel rispetto delle norme vigenti.
The installation of the appliance and all subsequent interventions must be carried out only by specialized personnel in compliance with current regulations.
L'installation de l'appareil et toutes les interventions ultérieures doivent être effectuées uniquement par du personnel spécialisé conformément à la réglementation en vigueur.
La instalación del aparato y todas las intervenciones posteriores deben ser realizadas únicamente por personal especializado en cumplimiento de la normativa vigente.
Die Installation des Geräts und alle nachfolgenden Eingriffe dürfen nur von Fachpersonal gemäß den geltenden Vorschriften durchgeführt werden.

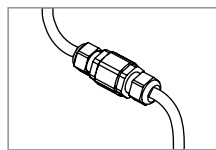

Il sistema di connessione apparecchio/linea di alimentazione, deve avere un grado di protezione IP uguale o superiore all'IP dell'apparecchio.
The connection system luminaire/power supply line, must have an IP protection degree equal to or higher than the IP of the appliance.
Le système de connexion luminaire/ligne d'alimentation, doit avoir un degré de protection IP égal ou supérieur à l'IP de l'appareil.
El sistema de conexión aparato/ línea de alimentación debe tener un grado de protección IP igual o superior a la IP del aparato.
Die Leuchte/Stromversorgungsleitung des Verbindungssystems muss einen IP-Schutzgrad aufweisen, der gleich oder höher als der IP des Geräts ist.

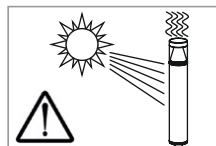

Assicurarsi che l'apparecchio non rimanga in funzione nelle ore diurne.
Make sure that the appliance does not remain in operation during the day.
Assurez-vous que l'appareil ne reste pas en fonctionnement pendant la journée.
Asegúrese de que el aparato no permanezca en funcionamiento durante el día.
Stellen Sie sicher, dass das Gerät tagsüber nicht in Betrieb bleibt

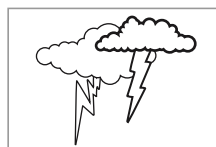

Si consiglia di utilizzare dispositivi di protezione dalle sovratensioni (SPD) nell'impianto per preservare l'apparecchio.
It is recommended to use surge protection devices (SPDs) in the system to preserve the device.
Il est recommandé d'utiliser des dispositifs de protection contre les surtensions (SPD) dans le système pour préserver l'appareil.
Se recomienda utilizar dispositivos de protección contra sobretensiones (SPD) en el sistema para preservar el dispositivo.
Es wird empfohlen, Überspannungsschutzgeräte (SPDs) im System zu verwenden, um das Gerät zu erhalten.



Il prodotto non deve stare a contatto con sostanze chimiche aggressive (es. fertilizzanti, diserbanti, calce).
The product must not be in contact with aggressive chemicals (eg fertilizers, herbicides, lime).
Le produit ne doit pas être en contact avec des produits chimiques agressifs (par ex. Engrais, herbicides, chaux).
El producto no debe estar en contacto con sustancias químicas agresivas (p. Ej. Fertilizantes, herbicidas, cal).
Das Produkt darf nicht mit aggressiven chemischen Substanzen (z. B. Düngemitteln, Herbiziden, Kalk) in Berührung kommen.



Non utilizzare alcool o prodotti chimici per la pulizia. E' consentito esclusivamente l'uso di un panno morbido imbevuto eventualmente con acqua e sapone non aggressivo.
Do not use alcohol or chemicals for cleaning. Only a soft cloth may be used, possibly soaked with water and non-aggressive soap.
N'utilisez pas d'alcool ou de produits chimiques pour le nettoyage. Seul un chiffon doux peut être utilisé, éventuellement imbibé d'eau et de savon non agressif.
No utilice alcohol ni productos químicos para limpiar. Solo se puede utilizar un paño suave, posiblemente empapado en agua y jabón no agresivo.
Verwenden Sie zum Reinigen keinen Alkohol oder Chemikalien. Es darf nur ein weiches Tuch verwendet werden, das möglicherweise mit Wasser und nicht aggressiver Seife getränkt ist.

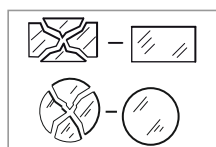

Sostituire i diffusori danneggiati, utilizzare solo ricambi originali.
Replace damaged diffusers, use only original spare parts.
Remplacez les diffuseurs endommagés, utiliser uniquement des pièces de rechange d'origine.
Reemplace las pantallas dañadas, utilizar solo repuestos originales.
Ersetzen Sie beschädigte Bildschirme. Verwenden Sie nur Originalersatzteile.



Il modulo LED può essere sostituito esclusivamente dal costruttore. Per la sostituzione si prega di contattare il rivenditore.
The LED module shall only be replaced by the manufacturer. For information, please contact your supplier.
Le module LED peut être échangé seulement par le constructeur. Pour le remplacement, veuillez contacter votre revendeur.
El módulo LED sólo puede ser reemplazado por el fabricante. Para más información, póngase en contacto con su proveedor.
Das LED-Modul darf nur vom Hersteller ersetzt werden. Für weitere Informationen, wenden Sie sich bitte an Ihren Lieferanten.

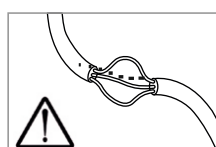

Sostituire il cavo flessibile esterno se danneggiato. Si raccomanda l'intervento soltanto da parte di personale specializzato.
Replace the external flex cable if damaged. Intervention is recommended only by specialized personnel.
Remplacez le câble flexible externe s'il est endommagé. L'intervention n'est recommandée que par du personnel spécialisé.
Reemplace el cable flexible externo si está dañado. La intervención es recomendada únicamente por personal especializado.
Ersetzen Sie das externe Flexkabel, wenn es beschädigt ist. Eingriffe werden nur von Fachpersonal empfohlen.



Non fissare la sorgente luminosa durante il normale funzionamento dell'apparecchio.
Do not stare at the light source during luminaire normal operation.
Ne pas regarder la source lumineuse pendant le fonctionnement normal du luminaire.
No mire fijamente a la fuente de luz durante el funcionamiento normal de la luminaria.
Blicken Sie während des normalen Betriebs der Leuchte nicht in die Lichtquelle.



DIRECTIVE 2012/19/UE
Il prodotto, alla fine della propria vita utile, dovendo essere trattato separatamente dai rifiuti domestici, deve essere conferito in un centro di raccolta differenziata per apparecchiature elettriche ed elettroniche, oppure riconsegnato al rivenditore.
The product, at the end of its useful life, has to be disposed of separately from household waste: it must be taken to a sorted collection centre for electrical and electronic appliances or returned to the retailer.
L'appareil, doit être traité séparément des déchets domestiques à la fin de son cycle de vie et remis à un centre de collecte différenciée pour équipements électriques et électroniques ou au revendeur.
El producto, al final de su vida útil, al tener que ser tratado por separado de los residuos domésticos, debe ser llevado a un centro de recogida separado de equipos eléctricos y electrónicos, o devuelto al distribuidor.
As Gerät nach seiner Nutzungsdauer nicht als Hausmüll, sondern über eine Wertstoffsammelstelle für elektrische und elektronische Altgeräte entsorgt werden bzw. dem Händler.

Tipo di installazione consigliata
 Recommended installation type
 Type d'installation recommandé
 Tipo de instalación recomendado
 Empfohlener Installationstyp

A Fischer

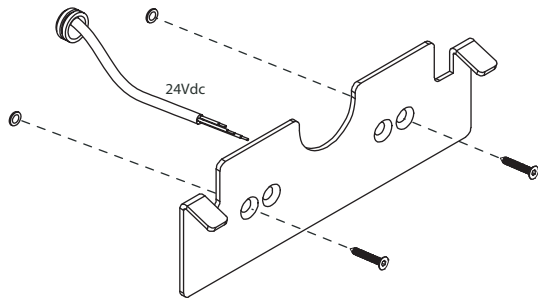

B Driver remoto

502E for 9200R
 or
 503E for 9201R - 9202R
 or
 504E for 9201R - 9202R

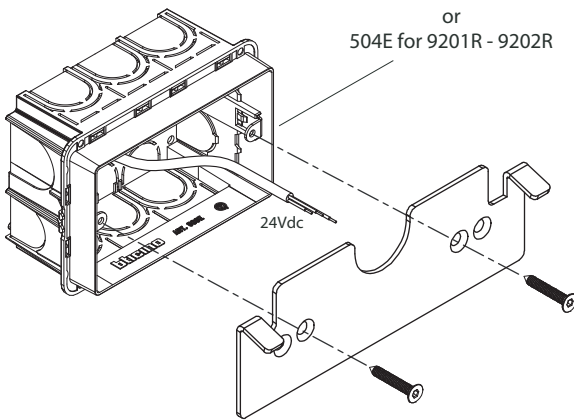

C Accessory Driver

502E 9200R
 or
 503E for 9201R - 9202R
 or
 504E for 9201R - 9202R

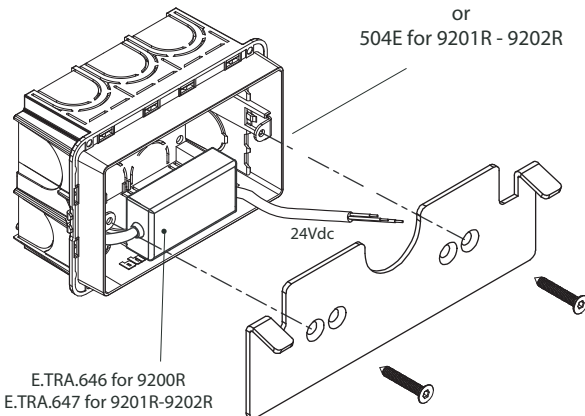

1A

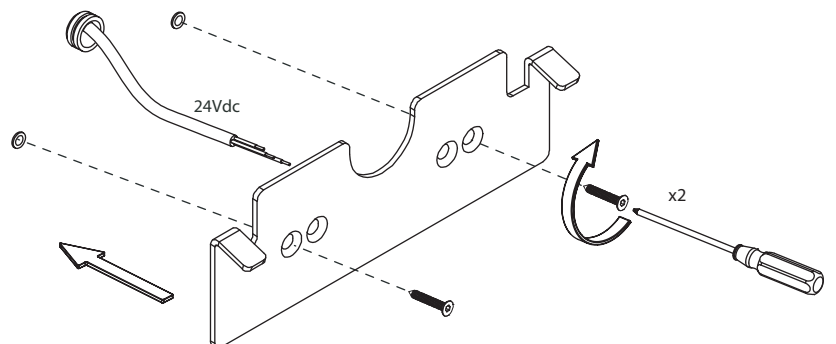
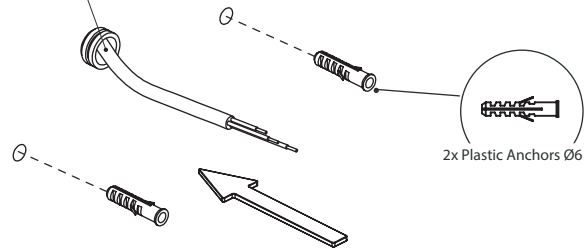
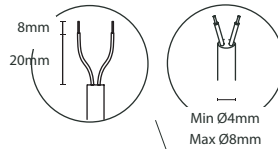
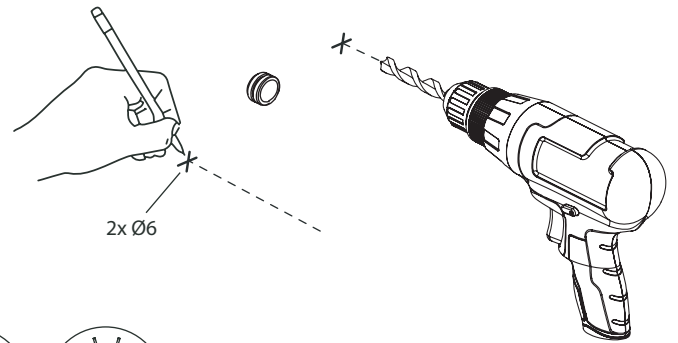
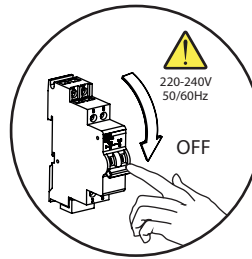
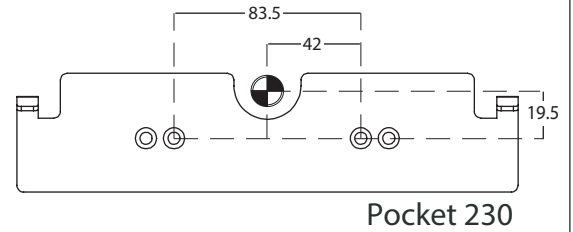
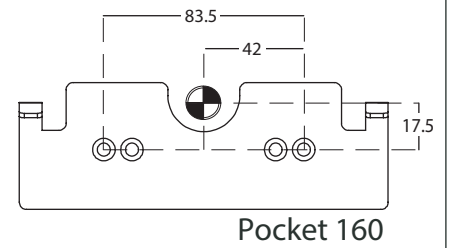
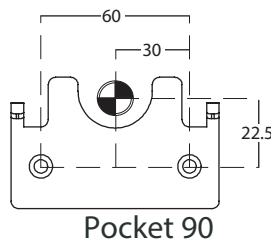

2A



Nastro Autoagglomerante (Non Fornito)
Self Vulcanising Tape (Not Supplied)
Ruban Auto Soudable (Non fourni)
Cinta Autoaglomerante (No suministrado)
Selbsthaftband (Nicht beiliegend)

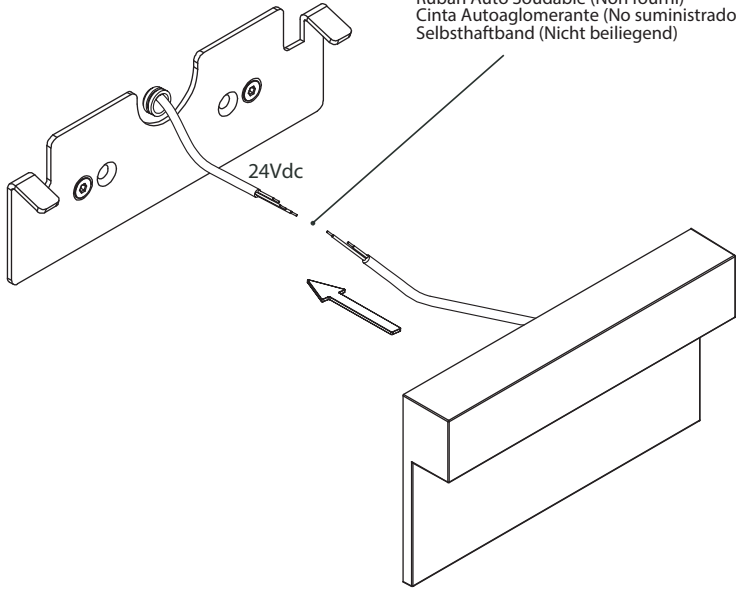

Rosso/Marrone - Red/Brown - Rouge/Marron - Rojo/Marròn - Rot/Braun



Nero/Blu - Black/Blue - Noir/Bleu - Negro/Azul - Schwarz/Blau

Cablaggio con Nastro Autoagglomerante (Non Fornito)
Wiring with Self Vulcanising Tape (Not Supplied)
Câblage avec Ruban Auto Soudable (Non Fourni)
Cableado con Cinta Autoaglomerante (No Suministrado)
Verkabelung mit Selbsthaftband (Nicht beiliegend)

Rosso/Marrone - Red/Brown - Rouge/Marron - Rojo/Marròn - Rot/Braun



Nero/Blu - Black/Blue - Noir/Bleu - Negro/Azul - Schwarz/Blau

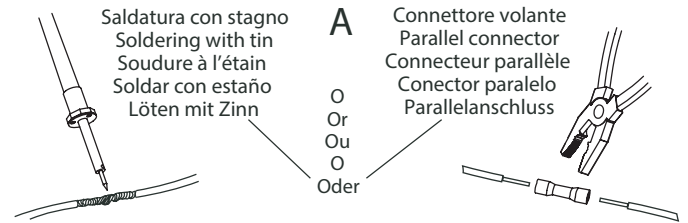

A Connettore volante
Parallel connector
Connecteur parallèle
Conector paralelo
Parallelanschluss

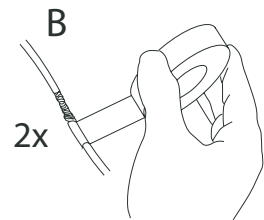

2x

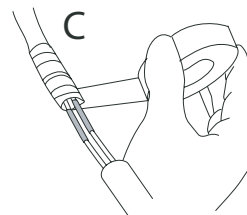

D ≥ IP67



Garantire una protezione minima equivalente a IP67
Provide a minimum protection equivalent to IP67
Fournir une protection minimale équivalente à IP67
Proporcionar una protección mínima equivalente a IP67
Stellen Sie einen Mindestschutz bereit, der IP67 entspricht

3A

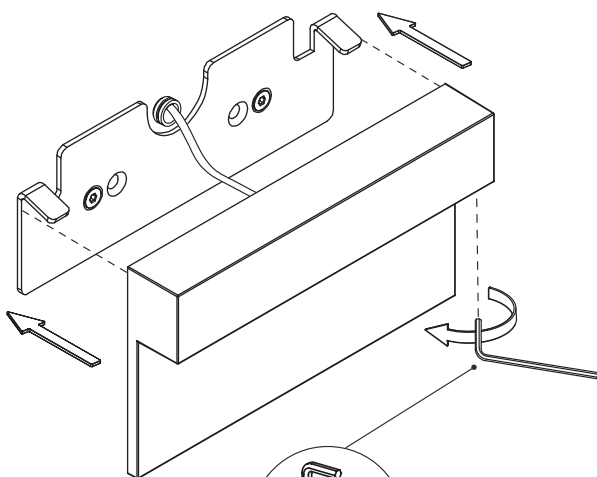

2x

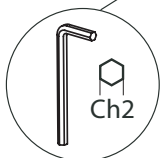

1B

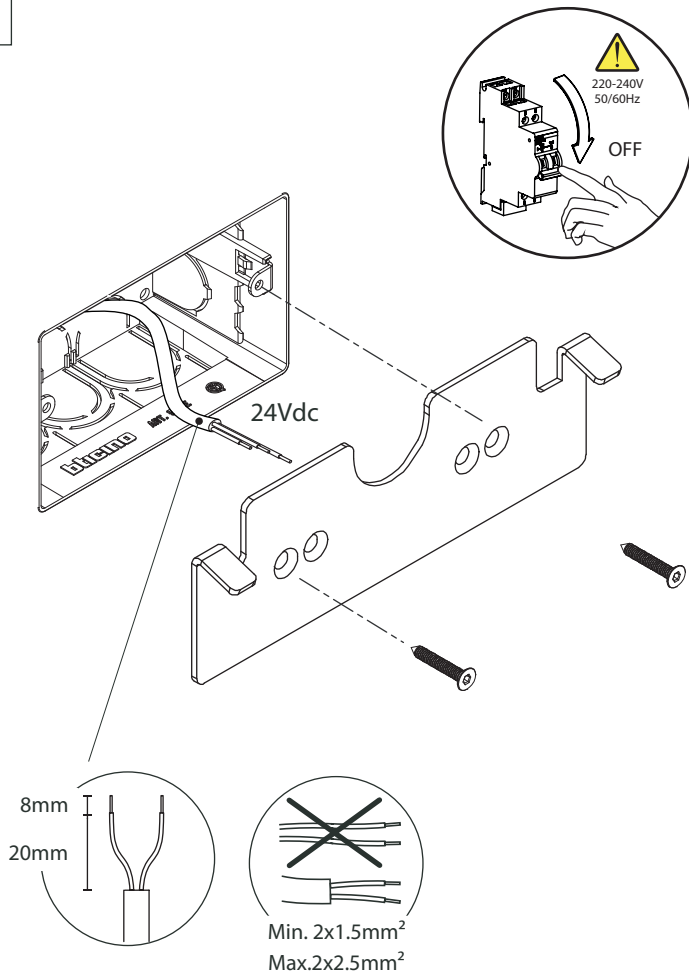

2B

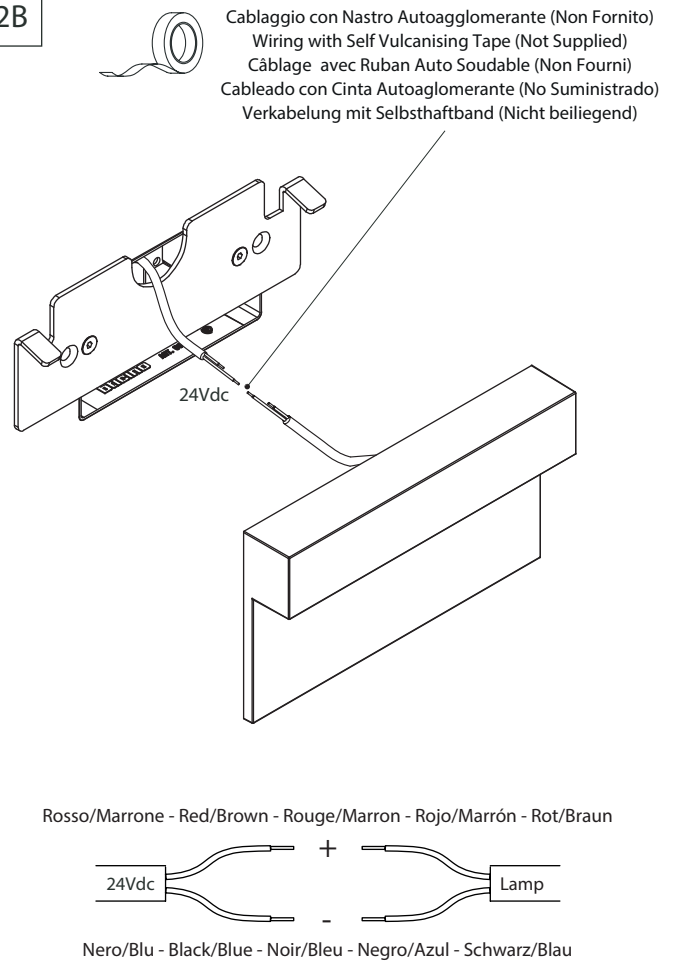

3B

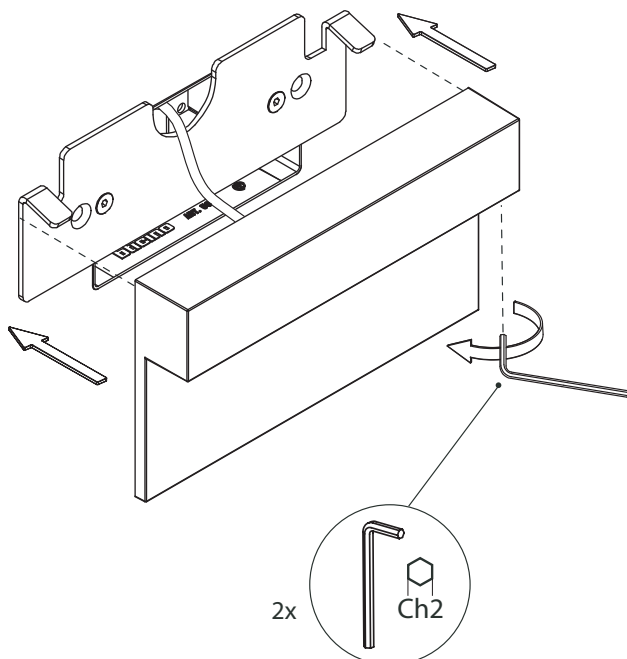

Cablaggio con Nastro Autoagglomerante (Non Fornito)
Wiring with Self Vulcanising Tape (Not Supplied)
Câblage avec Ruban Auto Soudable (Non Fourni)
Cableado con Cinta Autoaglomerante (No Suministrado)
Verkabelung mit Selbsthaftband (Nicht beiliegend)

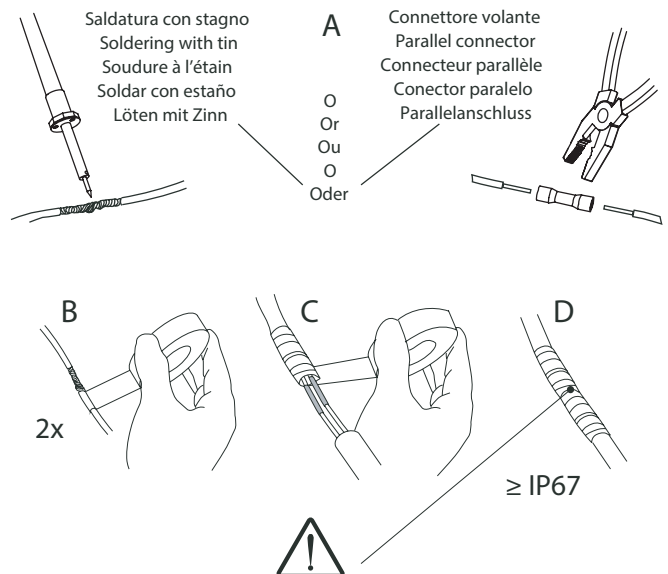

Garantire una protezione minima equivalente a IP67
Provide a minimum protection equivalent to IP67
Fournir une protection minimale équivalente à IP67
Proporcionar una protección mínima equivalente a IP67
Stellen Sie einen Mindestschutz bereit, der IP67 entspricht

1C

Cablaggio con Nastro Autoagglomerante (Non Fornito)
Wiring with Self Vulcanising Tape (Not Supplied)
Câblage avec Ruban Auto Soudable (Non Fourni)
Cableado con Cinta Autoaglomerante (No Suministrado)
Verkabelung mit Selbsthaftband (Nicht beiliegend)

E.TRA.646 for 9200R
OR
E.TRA.647 for 9201R - 9202R

Non Fornito
Not Supplied
Non Fourni
No Suministrado
Nicht beiliegend

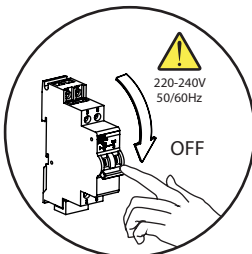
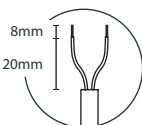
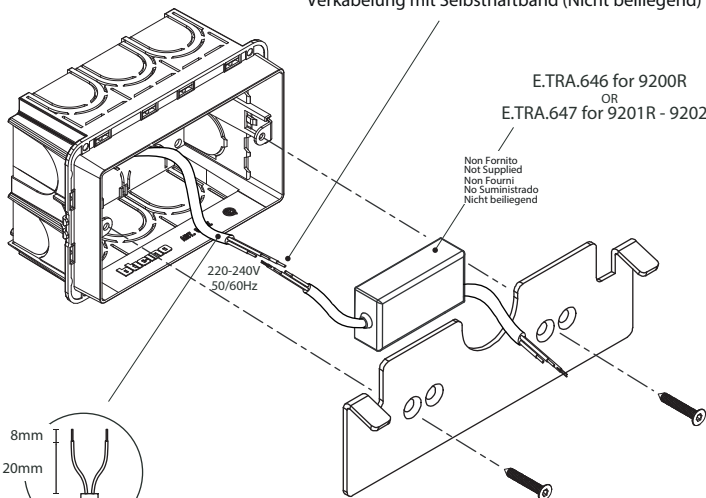

Rosso/Marrone - Red/Brown - Rouge/Marron - Rojo/Marrón - Rot/Braun

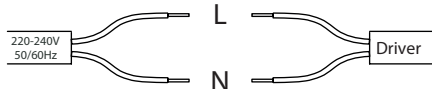

Nero/Blu - Black/Blue - Noir/Bleu - Negro/Azul - Schwarz/Blau

2C

Cablaggio con Nastro Autoagglomerante (Non Fornito)
Wiring with Self Vulcanising Tape (Not Supplied)
Câblage avec Ruban Auto Soudable (Non Fourni)
Cableado con Cinta Autoaglomerante (No Suministrado)
Verkabelung mit Selbsthaftband (Nicht beiliegend)

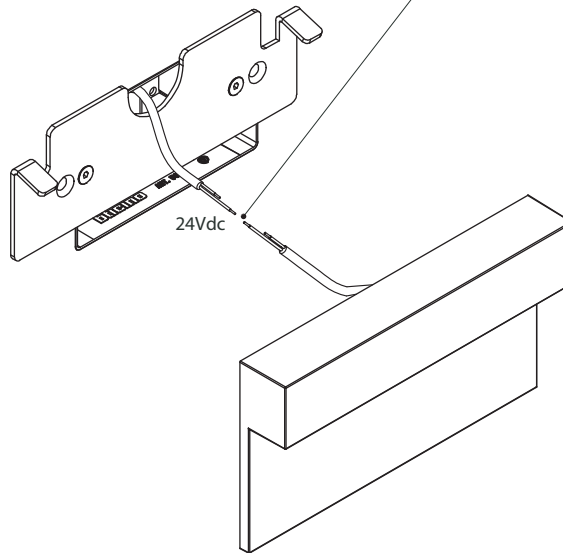

Rosso/Marrone - Red/Brown - Rouge/Marron - Rojo/Marrón - Rot/Braun

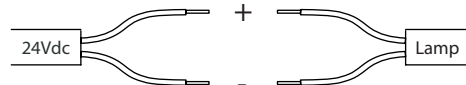

Nero/Blu - Black/Blue - Noir/Bleu - Negro/Azul - Schwarz/Blau

3C

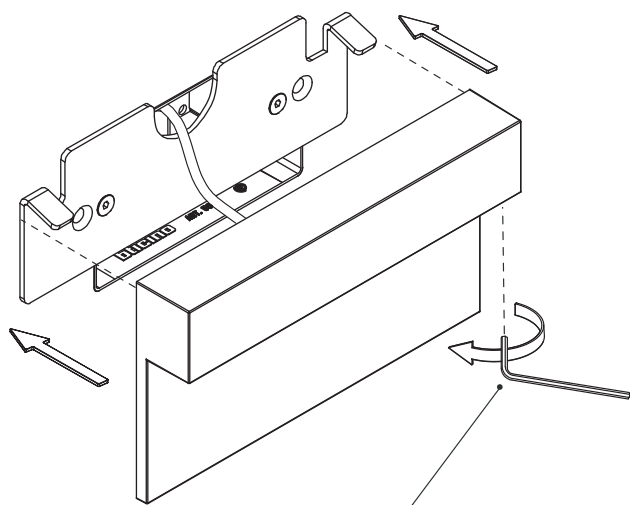

2x



Cablaggio con Nastro Autoagglomerante (Non Fornito)
Wiring with Self Vulcanising Tape (Not Supplied)
Câblage avec Ruban Auto Soudable (Non Fourni)
Cableado con Cinta Autoaglomerante (No Suministrado)
Verkabelung mit Selbsthaftband (Nicht beiliegend)

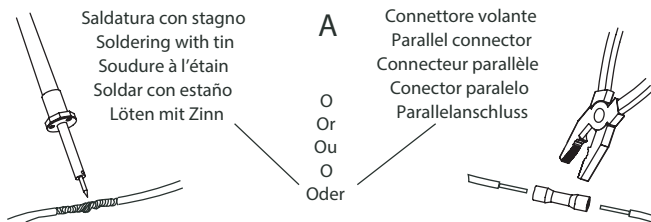

Saldatura con stagno
Soldering with tin
Soudure à l'étain
Soldar con estaño
Löten mit Zinn

A
Connettore volante
Parallel connector
Connecteur parallèle
Conector paralelo
Parallelanschluss

O
Or
Ou
O
Oder

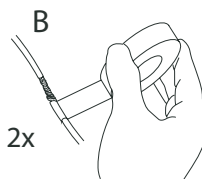

2x

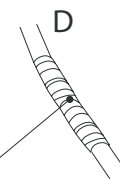
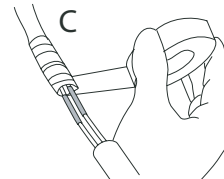

≥ IP67



Garantire una protezione minima equivalente a IP67
Provide a minimum protection equivalent to IP67
Fournir une protection minimale équivalente à IP67
Proporcionar una protección mínima equivalente a IP67
Stellen Sie einen Mindestschutz bereit, der IP67 entspricht